



Electronic Service Inc.

VIESSMANN

VITOTALK

KW Electronic Service Inc. and Viessmann, partners in heating technology. Controls newsletter, May 2002, Issue 2

Thank you to everyone who responded to our first edition of VITOTALK.

We hope to bring you some insightful topics in the following issues.

Did You Know???

KR Control

From time to time, a KR Boiler Control is used as a building management interface to a Viessmann boiler. The KR is only capable of controlling a two stage burner. To fully modulate the burner, the BMS must control the burner modulation directly.

vvvvvvvvvv

Override Mode Button

The override button does not control the mixing valve. During times of uncertain control operation, be aware that when the override button is pressed, the mixing valve continues to operate as it normally would. It may be necessary to set the mixing valve position manually.

vvvvvvvvvv

Vitotronic 200/300 Coding

Coding level 2 in the Vitotronic 200 and 300 boiler controls is divided into multiple groups. The groups are: Boiler/Burner, DHW, General, Boiler Circuit, Mixing Circuit 1 and Mixing Circuit 2. The Vitotronic 200 does not have "mixing circuit 2" as an option. Be very careful where you change an address—you may change a value in the incorrect group

vvvvvvvvvv

Vitotronic KK10/KW10

The DHW priority in the Universal Pump Module cannot be removed.

Leading Word on Lag Modules

There are many reasons for installing two smaller boilers instead of one. Having the backup of an extra boiler is one very good reason. But, probably the best reason is to minimize operating costs. One small boiler can satisfy the heat load for the majority of the year. The lag boiler can be enabled only when it needs to be. This will reduce excessive burner cycling of the larger boiler which may lead to fuel savings.

You may be asking yourself, "How do I do this?". Well, there are a couple of methods depending on the control and boiler installed.

The first method is the **Lead-Lag Expansion Kit**. This kit is used exclusively with Vitotronic 200 and 300 controls on single stage boilers only.

The kit (Vi P/N 7133 897) includes the 2 stage/modulating control, dual #3 sensor and thermometer.

The thermometer is required because of the dual #3 averaging boiler sensor.

It is necessary to know the actual boiler temperature of the lead boiler.

The dual boiler sensor is plugged into the same socket where the single boiler sensor would go, if it were installed.

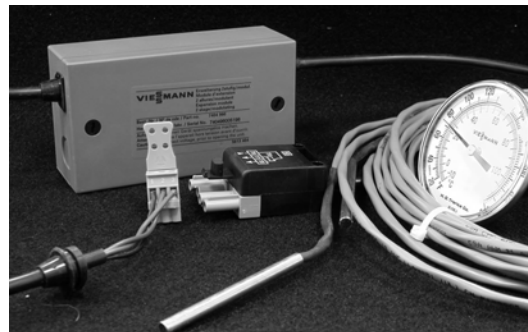

Above: Lead-Lag Expansion Kit parts. Gauge, Sensor, Control

Below: Inside of 2 stage/modulating control showing relays



The 2 stage/modulating control is plugged into the 191 socket of the Vitotronic control. This is a light coloured green plug. The 191 plug is not part of the "Automatic Recognition" family of sensors that the Vitotronic uses. The installer must enter the Vitotronic coding and change address 02 from 00 to 01.

The 2 stage/modulating control is comprised of two relays. This combination allows for both staging and modulation. When the control enables the second stage, the second stage relay is de-energized. The normally closed contact will then enable the lag boiler. This action is similar to a call for heat from a room thermostat.

At the opposite end of the staging



Continued from page 1

control, there is a male and female 90 plug. The installer must connect the room thermostat connection of the KK5/KK10 boiler control (terminals X2.1 and X2.2) into the female 90 plug into terminals T6 and T8. The length of this connection may be long or short depending on the distance between the two boilers.

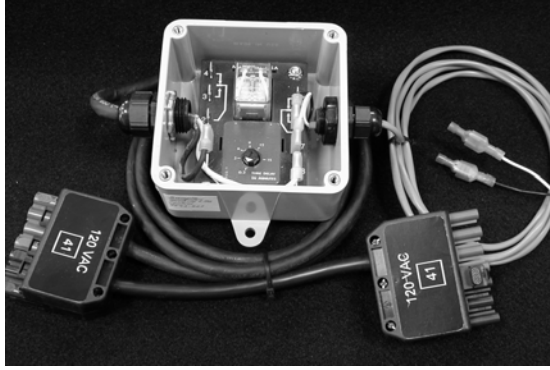

Cover removed from Universal Lag Control enclosure

Approximately 6 feet of two conductor wire is included for the room thermostat connection. Both wires are terminated with a male crimp-on terminal. The corresponding female terminal is plugged onto the male terminal. The installer must add a length of wire between the control thermostat connections and the female connectors. Again, this length of wire will depend on the distance between the boilers.

IT CAN BE A SLIPPERY SLOPE TO THE WWSD POINT!

The question has been asked "What is the difference between the heating curve logic for a KW10 versus the Vitotronic 200 and 300 controls?".

At first glance, the heating curve charts looks very similar, but there are fundamental differences. The first visible difference is how the heating curve looks. You will note that the Viessmann heating curves have an arc to them. The outdoor and boiler/supply temperature is of a non-linear relationship.

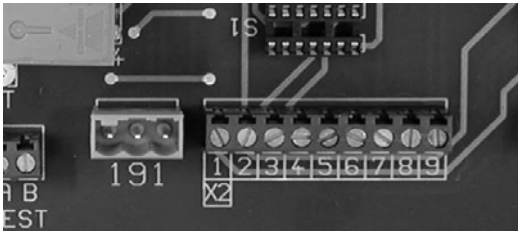

Picture shows the room t-stat connections on X2

There are a number of address that may be modified for two stage set ups. As with previous versions of Trimatiks, the burner switching may be changed from a fixed differential to a load dependant basis.

The second lag control available is the **Universal Lag Control** (Vi P/N 9543 427. Along with the Vitotronic 200 and 300, this control can be used with the Vitotronic 100 KK10 or KW10.

The last staging control is called the **Adjustable Timer Module** (Vi P/N 7133 912). It is used exclusively on two stage boilers with a KK10 where boiler staging is achieved by single-stage thermostat or set point control. An adjustable timer delay can be set from 6 seconds to 8 minutes.

As with all two stage boilers, the second stage control is resident on the boiler from the factory. It is the same control that is used in the Lead-Lag Expansion Kit.

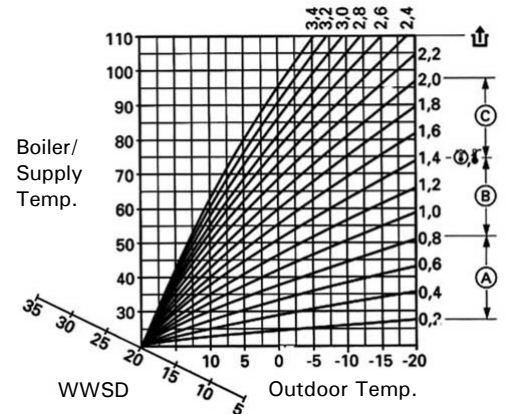

The heating curves of the KW10 are much flatter. The relationship is more linear than that of the Viessmann curve.

The lag control is plugged in between the 41 plug coming from the control and the burner 41 plug. When a call for heat originates from the lead boiler control, the timer will start. After the preset time has elapsed, the lag boiler will detect the call for heat. The range of delay is adjusted from 0.2 minutes to 15 minutes. It should be noted that there is no minimum time that the lag boiler will operate for. If the call for heat of the lead boiler is satisfied, the lag boiler will turn off immediately.



Inside of Adjustable Timer Module shown

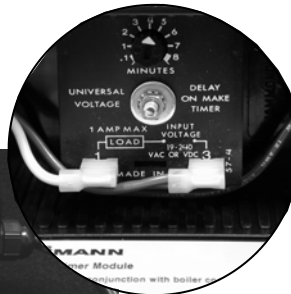

All of these methods work very well when

applied correctly. If you are dealing with a system greater than two boilers, the best method of control is a Multimatik control panel. The Multimatik is built to suit every application. Unlike the standard lag control, one feature of the Multimatik control is to allow the boilers to rotate along with staging.

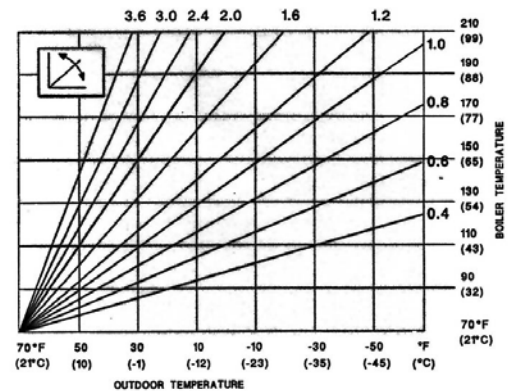

The second difference is the number adjustments that can be made by each outdoor reset controller. The Viessmann control allows a slope adjustment, parallel shift adjustment and a WWSD adjustment. Whereas the KW10 only allows a slope and a WWSD adjustment.

Continued from page 2

While this may not sound like a big difference, it will impact on how the controls ultimately operate and calculate.

For a moment, lets recap the fundamental operation of the heating curve.

The slope adjustment of a heating curve changes the relationship of outdoor temperature to boiler/supply temperature. A lower heating curve (0.6) will calculate a relatively cooler boiler/supply temperature than that of a higher heating curve (2.6). In other words, the lower the heating curve, the less the outdoor temperature effects calculated boiler/supply temperature. The higher the heating curve, the greater the outdoor temperature effects boiler/ supply

temperature calculations. The Vitotronic 200/300 and KW10 both have an adjustable warm weather shutdown point (WWSD). The WWSD point is located at the bottom of the heating curve chart. It is shown as a diagonal line to that of the X and Y axis.

To understand the effects that the WWSD has on the heating curve, envision all of the selectable curves coming to one single point on this line. Now envision this single point moving up an down on the diagonal line. As this point moves, the boiler/supply temperature recalculates with respect to outdoor temperature. Please keep in mind that this is not necessarily a parallel shift. A change in the WWSD

point will not provide the same change in temperature at the end of the heating curve.

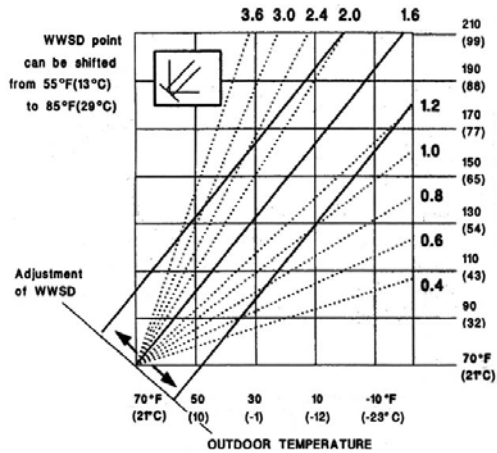

boiler temperature.

The sun and moon adjustments control the WWSD point in the Vitotronic 200/300 controls. The daytime and set back modes are dependant on the timer settings programmed into the boiler control. As with most Viessmann controls, the factory timer settings are from 06:00 to 22:00

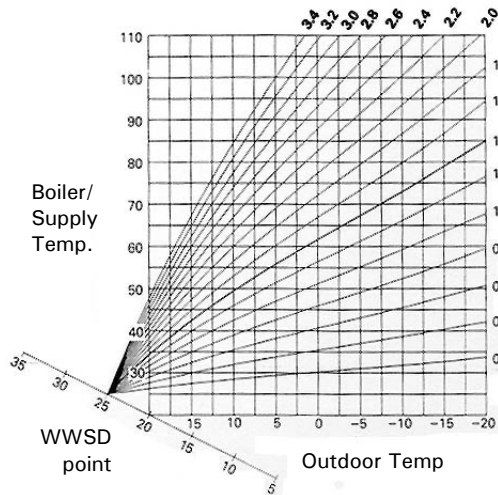

The WWSD adjustment on the KW10 is a small dial on the front of the control. It has a generic WWSD symbol on the label.

One remaining feature that the Vitotronic 200/300 control has, that the KW10 doesn't, is a parallel shift adjustment. It is the parallel shift that

truly enables the user to calibrate the heating curve to their needs. If a zone requires high temperature with very little reset, it is only possible with this adjustment. Now, if the same user installed a boiler with a KW10 control to supply heat to the same zone, the settings would be entirely different. The WWSD would have to be adjusted to maximum and the heating curve may have to be adjusted to a higher value. These settings may overheat the space when heat is no longer required

because of the increased WWSD point.

Whether a Vitotronic KW10 or a 200/300 is used, it is very important that the heating curve be set to provide customers with maximum comfort yet still provide fuel savings.

A Little KW10 Tidbit

The KW10 outdoor reset control has a built in diagnostic system with a small square flashing light on the PCB. If ever you encounter a KW10 control that is operating in a manner you don't expect, look for this indicator.

If the failure is with the outdoor temperature sensor, the outdoor reset board will assume a value of 0°C/32°F. This may overheat during certain times of the year and provide not enough heat during the winter months.

If the failure is with the boiler sensor, the burner will not fire at all. Check for the little flashing light.

Temperature Degrees F and C		Resistance Ohms
-40F	-40C	337,000
-20F	-29C	166,000
-10F	-23C	116,000
10F	-12C	61,700
30F	-1C	34,400
50F	10C	19,900
70F	21C	11,900
90F	32C	7,400
110F	43C	4,730
130F	54C	3,100
150F	66C	2,010
170F	77C	1,390
200F	93C	838

Please send input to:
 KW Electronic Service Inc.
 750 McMurray Road,
 Waterloo, Ontario, Canada,
 N2V 2G5
 Tel: (519) 747-5042
 Fax: (519) 747-4448
 jeff@kwelectronicsservice.com

A Little Electrical Theory Revisited: 41 Plug

WARNING!

Turn off electric power supply before servicing electrical devices. Contact with live electric components can cause shock or loss of life. If you don't know what you are looking at, or what it does, don't touch it!

In the last issue of Vitotalk, the basic series circuit was explored. Let's review what we know at this point:

1. A series circuit has a single conductive path for current flow.
2. The sum of the voltage drops around the circuit equals the applied voltage.
3. The load offers restriction to current flow thereby determining the total amperage draw from the power supply.
4. Any open switching device within the series circuit will prevent voltage from being applied to the load.

The 41 plug for the Vitotronic KK/KW model is shown here. This is the best example of a series circuit, with respect to Viessmann controls.

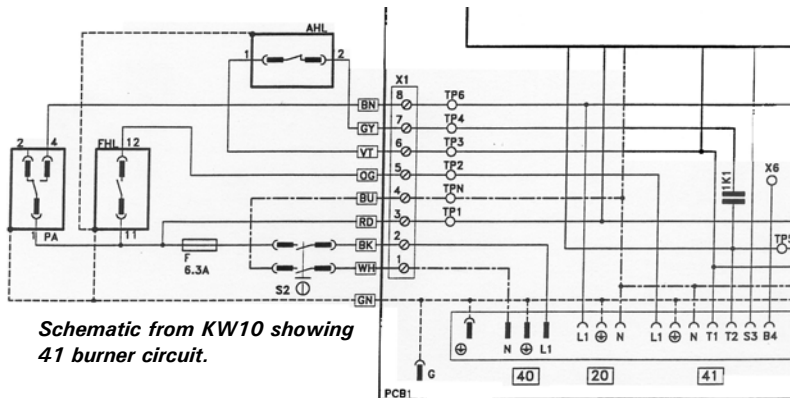

Schematic from KW10 showing 41 burner circuit.

Referring back to the schematic, the next component that is shown is the main fuse. This fuse has the responsibility of protecting the entire control from excessive current draw.

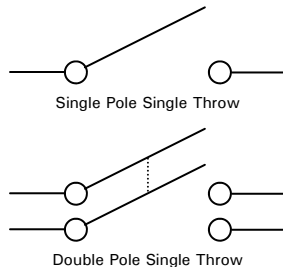

As we mentioned earlier, any one device in a series circuit that becomes "open" will interrupt the

flow of current through the entire circuit.

The next major component in the 41 plug circuit is the Fixed High Limit (FHL). The FHL is a simple switch that

Power flow re-enters the control on terminal T1 and then flows through the Adjustable High Limit (AHL).

The AHL is just another safety switch in the 41 plug circuitry. Similar to that of the FHL, if the AHL is opens during normal operation, the call for heat is taken away from the burner.

The last control device immediately after the AHL is the main operating contact. This is the only true "operator" in the entire 41 plug circuit. All of the other devices are safety control devices

LARGER BURNERS

It is necessary to supply power to the flame safeguard controls of larger burners. Any Weishaupt burner that uses a LFL control requires power to always be present. Instead of installing a jumper between the L1 terminal and T2, the LFL must always be powered.

The basic test for this operation is to lock the burner out by pressing lightly on the oval window of the LFL. If the burner locks out, power is being supplied to the LFL. If it doesn't lock out, the LFL is powerless. Check the

As we know, all electrical circuits need a power source. All Viessmann controls use the green "40" plug for the power source connection. In the field, this may be seen as a terminal rail connection inside a junction box, a power cord connected to a 40 plug or hardwire connections inside a PPM.

The next component we need is the power switch. The power switch is required to provide a 'local' disconnect for the control. The power switch in the circuit example shown in the first issue of Vitotalk is known as a single pole, single throw switch. All Viessmann controls switch both the line and neutral connections of the circuit. These switches are known as double pole/single throw.

opens on high temperature. Assuming the FHL is not tripped, the current path continues to the L1 terminal in the 41 plug.

Unlike the larger burners, the smaller residential Riello and Viessmann Chassis burners do not need a continuous power source to the flame safeguard control. Instead, a jumper is installed between L1 and T1 terminals.

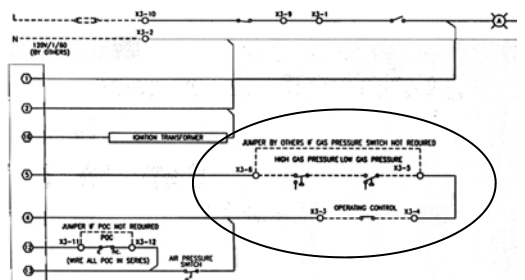

The above section of burner schematic shows how the operating control (Viessmann boiler control) is in a series circuit with the high and low gas pressure switches. When either the operating control, the high pressure switch or low pressure switch opens, the burner will shut down. The gas pressure switches are a manual reset switch.

The following page shows some other examples of other Viessmann controls.

A Little Electrical Theory Revisited: 41 Plug Continued

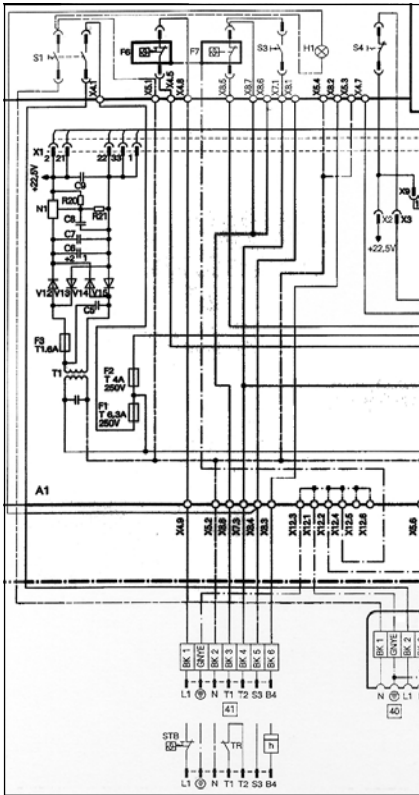

41 Schematic of KR Control

The schematics shown on this page are other examples of the 41 burner plug. While they may differ in fine detail, the basis of operation in each control is identical.

Incoming Power Supply

Low Water Cutoff

40 Plug

Power Switch

Fuse

Fixed High Limit
FHL

L1 of 41 Plug to Burner

Burner or jumper

T1 of 41 Plug Back Into Control

Adjustable High Limit
AHL

Outdoor Reset or
Room Thermostat Controlled
Enable Contact

T2 Into Burner

Burner
Safety Circuit

Burner Cycle

Ignition

Heat

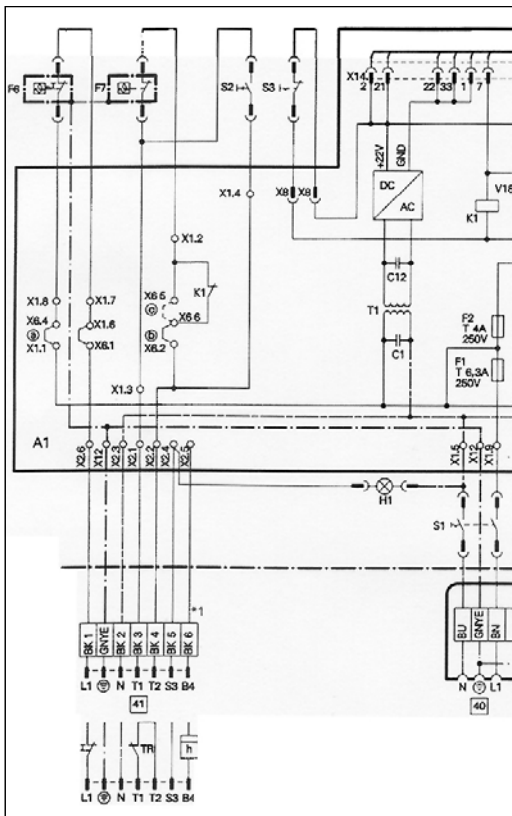

41 Schematic of Trimatik RN Control

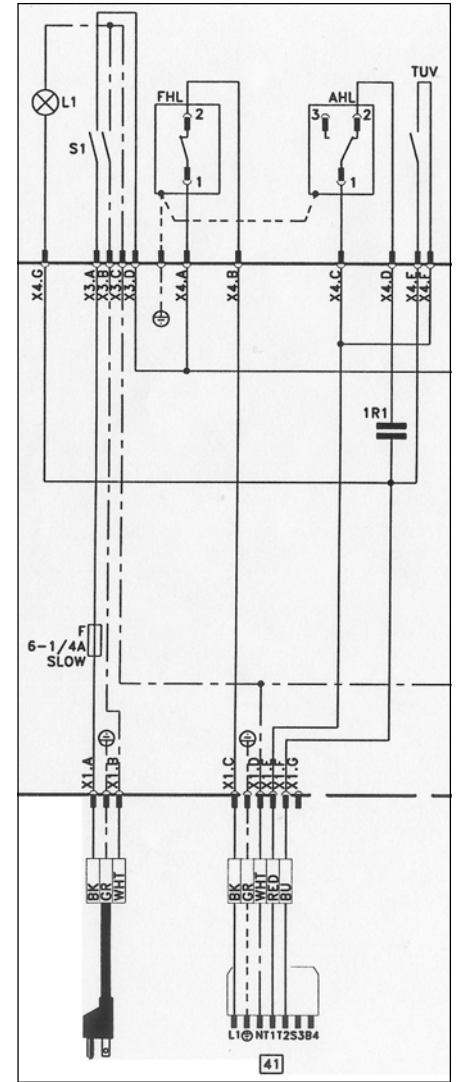

41 Schematic of SR-V Control

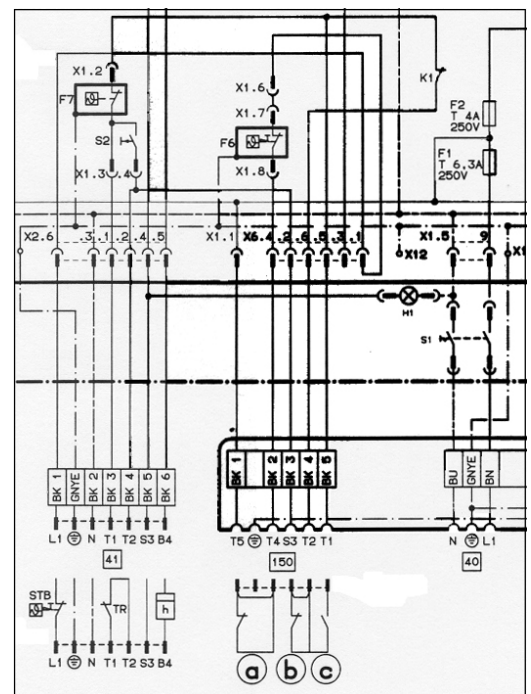

41 Schematic of Dekamatik M1 Control

The next issue of Vitotalk will continue with some great suggestions faxed in.